

Ultralisk (from StarCraft)

Author / auteur : Jérémy Duez

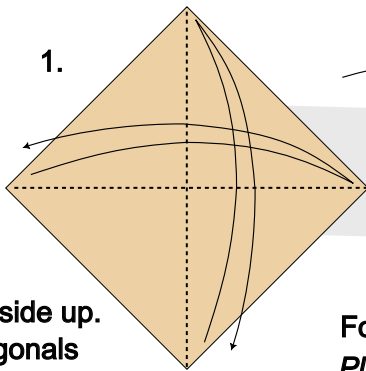



1.

Colored side up.
Fold diagonals
and unfold
*Face avec couleur
de votre côté.
Plier les diagonales
et déplier*

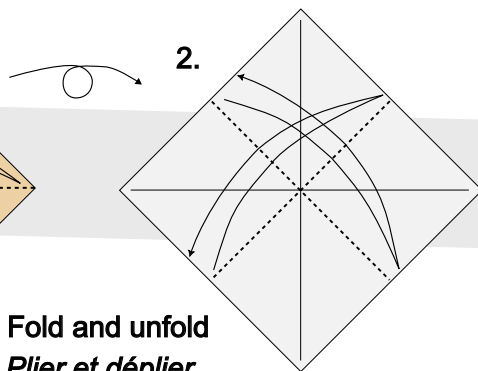

2.

Fold and unfold
Plier et déplier

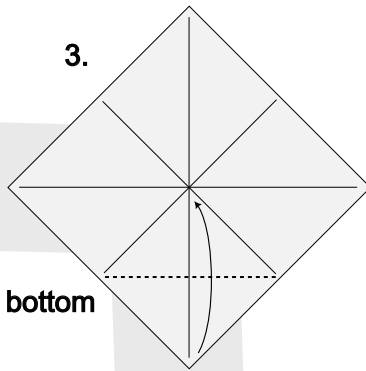

3.

Fold the bottom
flap up
*Plier le bord inférieur
en haut*

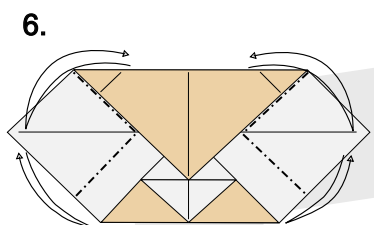

6.

Mountain folds and unfold
Plis montagnes et déplier

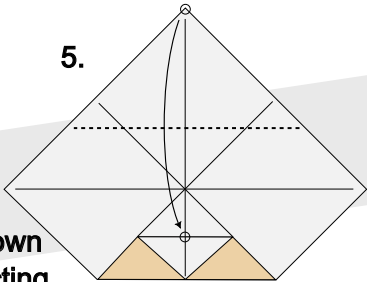

5.

Fold down
connecting
circled points
*Plier vers le bas
en rejoignant
les cercles*

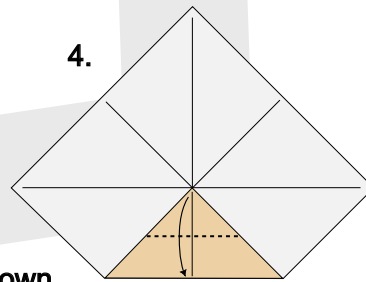

4.

Fold down
Plier vers le bas

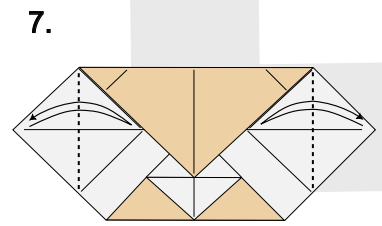

7.

Fold and unfold
Plier et déplier

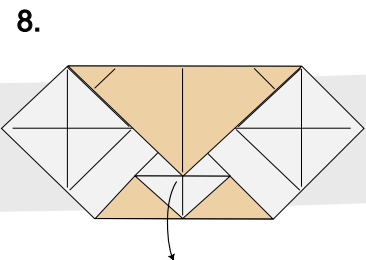

8.

Unfold bottom
Déplier le bas

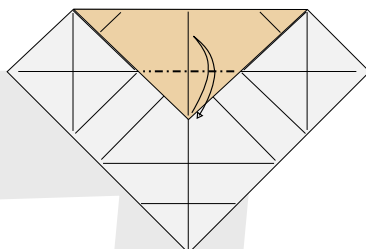

9.

Mountain fold and unfold
Pli montagne et déplier

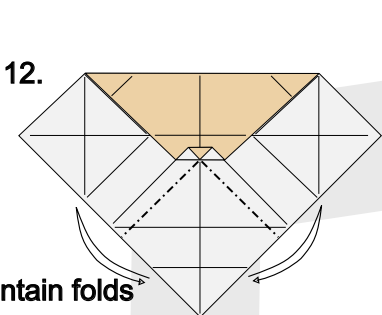

12.

Mountain folds
and unfold
*Plis montagnes
et déplier*

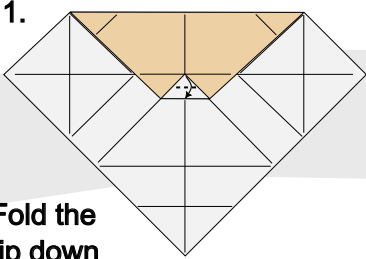

11.

Fold the
tip down
*Plier la pointe
vers le bas*

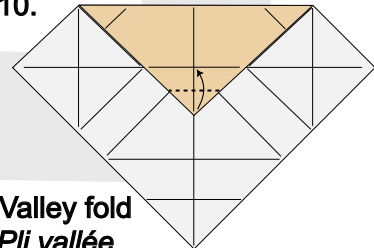

10.

Valley fold
Pli vallée

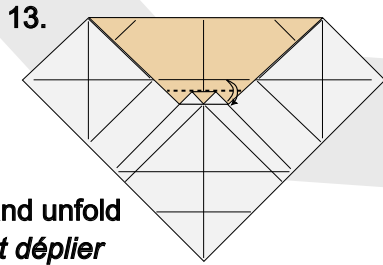

Fold and unfold
Plier et déplier

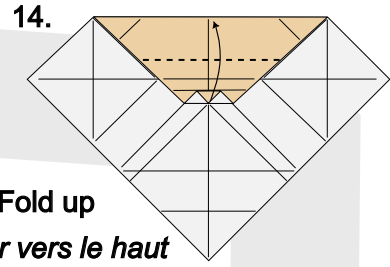

Fold up
Plier vers le haut

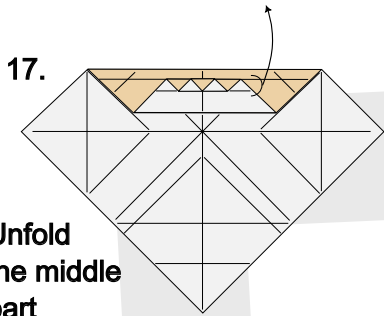

Unfold the middle part
Déplier la partie du milieu

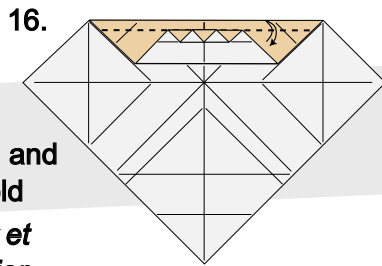

Fold and unfold
Plier et déplier

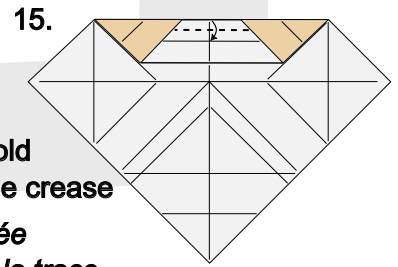

Valley fold using the crease
Plis vallée utilisant la trace du pli

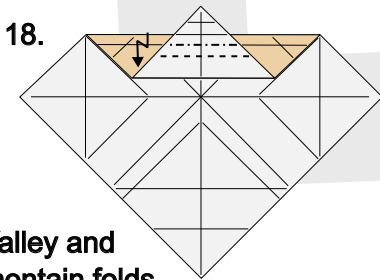

Valley and mountain folds
Plis vallée et montagne

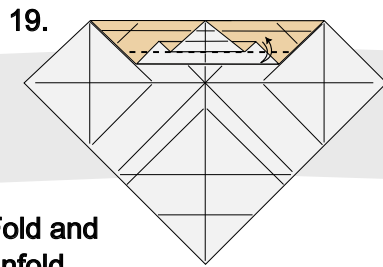

Fold and unfold
Plier et déplier

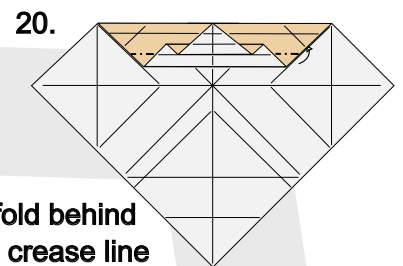

Mountain fold behind using the crease line made in 20
Pli montagne derrière en se servant de la marque faite en 20

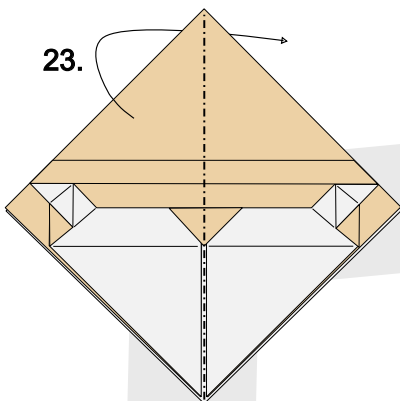

Fold the model in half
Plier le modèle en deux

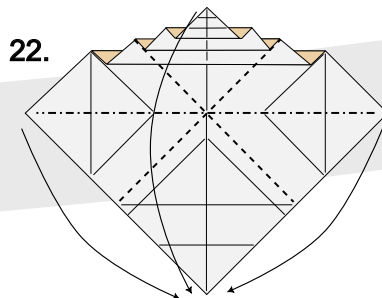

Preliminary fold
Pli préliminaire

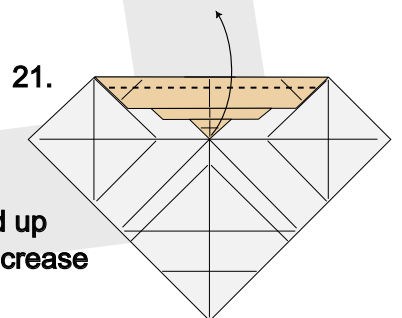

Valley fold up using the crease line
Pli vallée vers le haut en utilisant la marque

24.

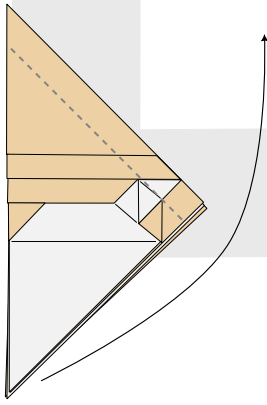

Inside reverse fold
using the crease inside

*Pli renversé intérieur
sur le pli marqué à l'intérieur*

25.

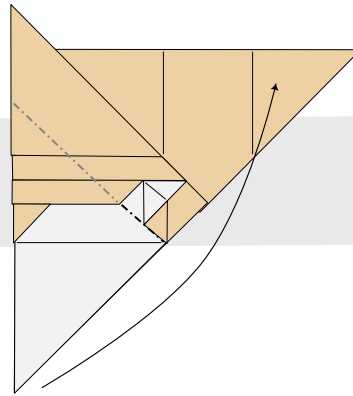

Inside reverse fold
using the crease inside again

*Pli renversé intérieur encore
sur le pli marqué à l'intérieur*

26.

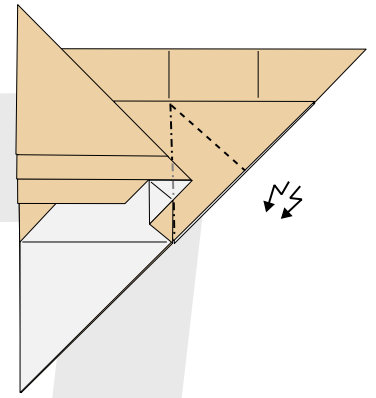

Crimp inside

Repli à l'intérieur

29.

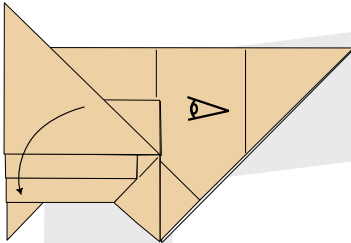

Open the middle part.
Inside view

*Ouvrir la partie du milieu.
Vue de l'intérieur*

28.

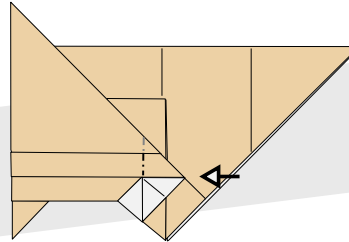

Inside reverse fold.
Don't fold the top part

*Pli renversé intérieur.
Ne pas plier la partie du haut*

27.

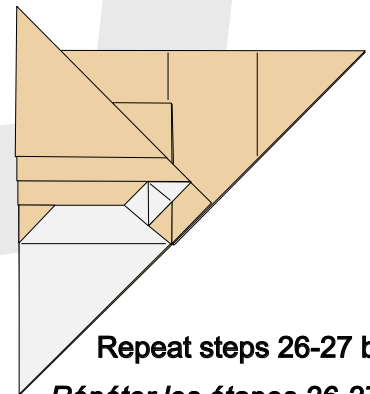

Repeat steps 26-27 behind
Répéter les étapes 26-27 derrière

30.

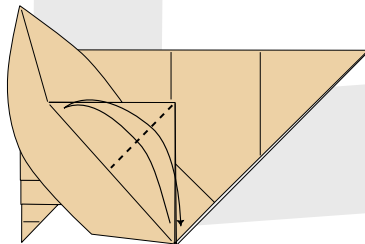

Fold and unfold
Plier et déplier

31.

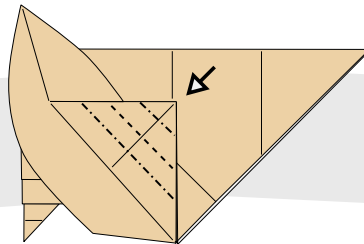

Make a series of open sink
in and out

*Faire une série d'enfoncement
dedans et dehors*

32.

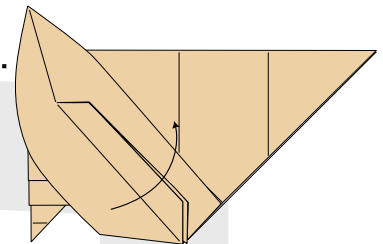

Close the model

Fermer le modèle

35.

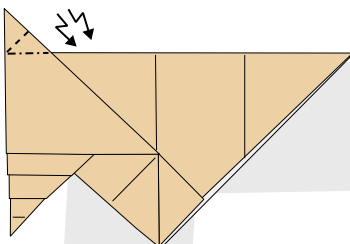

Crimp inside (2 layers)
Repli à l'intérieur (2 couches)

34.

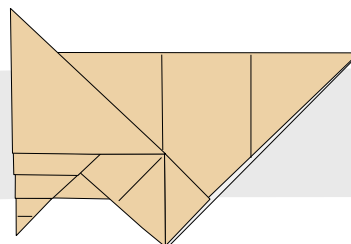

Repeat steps 29-34 behind
*Répéter mes étapes 29-34
derrière*

33.

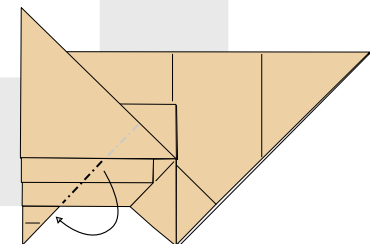

Inside reverse fold
Pli renversé intérieur

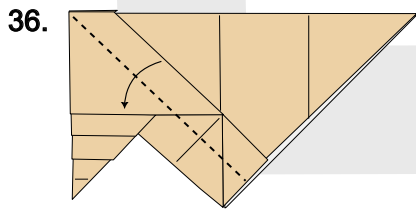

36. Valley fold 2 flaps
Pli vallée 2 couches

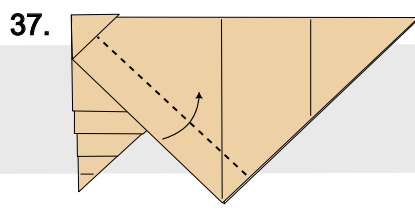

37. Valley fold 1 flap
Pli vallée 1 couche

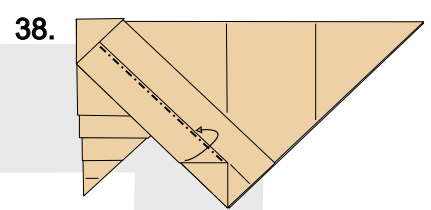

38. Mountain fold the flap into the slot immediately behind
Pli montagne le côté dans l'interstice immédiatement derrière

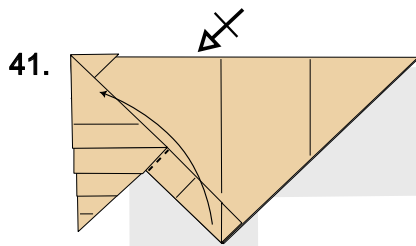

41. Fold two flaps up. repeat behind
Plier deux côté vers le haut. Répéter derrière

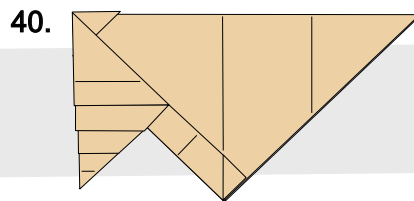

40. Repeat steps 37-40 behind
Répéter mes étapes 37-40 derrière

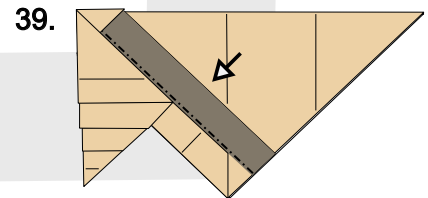

39. Push the darkened part (closed sink on top)
Enfoncer la partie foncée (Pli enfoncé fermé en haut)

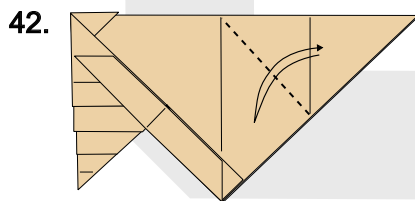

42. Fold and unfold
Plier et déplier

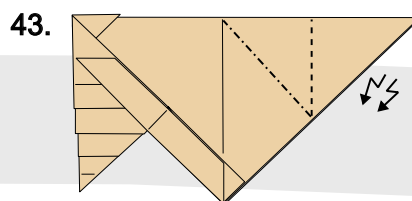

43. Crimp inside
Enfoncer à l'intérieur

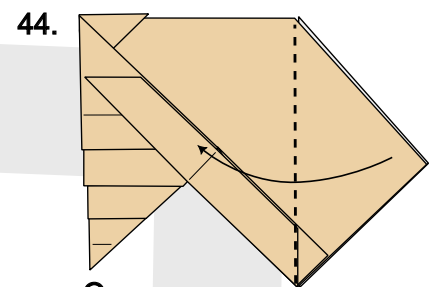

44. Open
Ouvrir

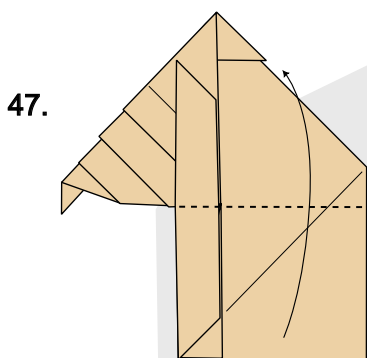

47. Fold the first flap up
Plier le premier côté vers le haut

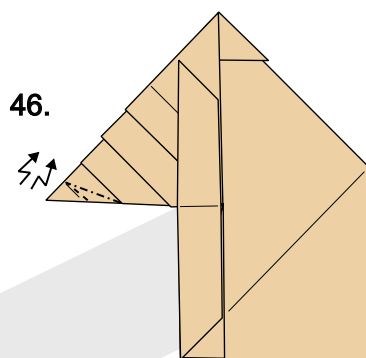

46. Crimp inside
Enfoncer à l'intérieur

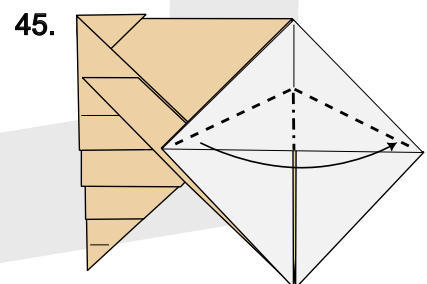

45. Pleat as indicated closing the model
Plier comme indiqué en formant le modèle

48.

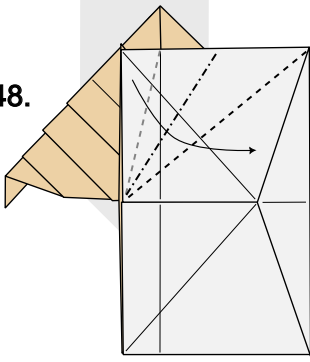

Squash fold
Pli écrasé

49.

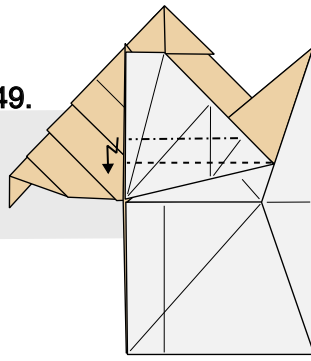

Fold as indicated
Plier comme indiqué

50.

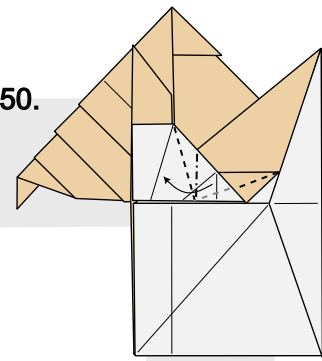

Petal fold
Pli pétal

53.

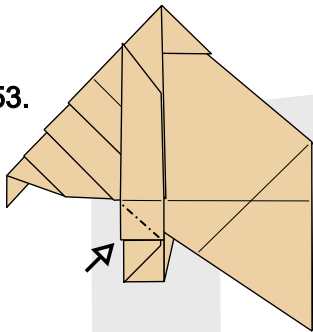

Inside reverse fold inside
Pli rentré intérieur

52.

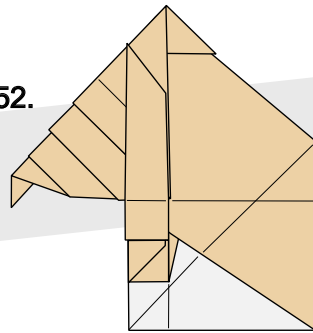

Repeat 48-52 behind
Répéter 48-52 derrière

51.

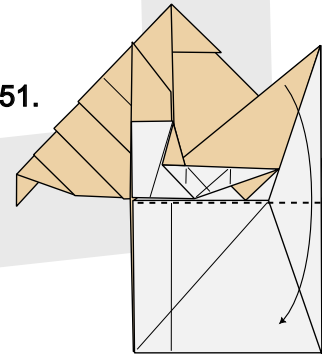

Fold down the legs
Plier les pattes vers le bas

54.

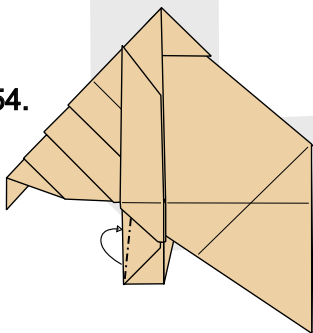

Montain fold behind
Pli montagne derrière

55.

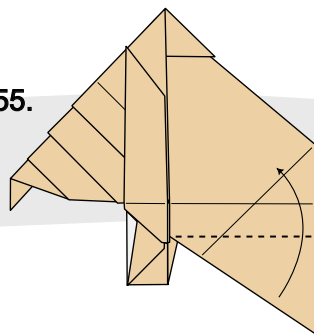

Fold the flap up
Plier vers le haut

56.

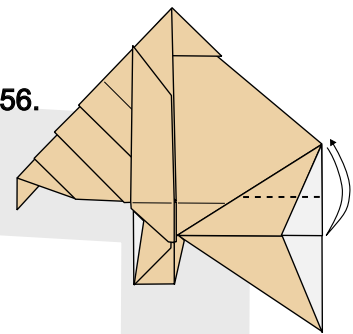

Fold and unfold
Plier et déplier

59.

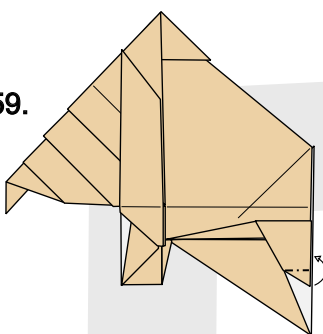

Fold the tip behind
Plier le bout derrière

58.

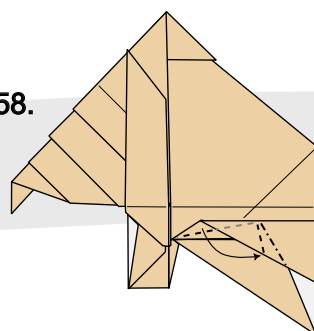

Pleat inside
Plier à l'intérieur

57.

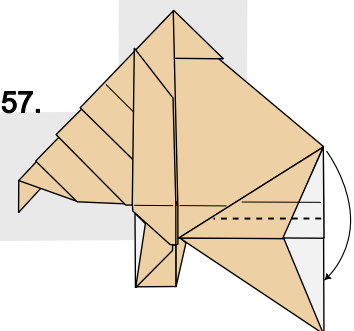

Fold down
Plier vers le bas

60.

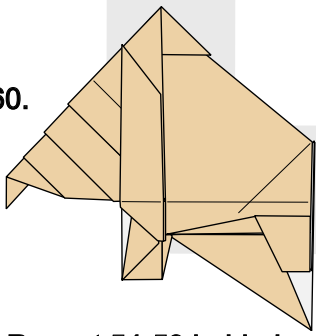

Repeat 54-59 behind
Répéter 54-59 derrière

61.

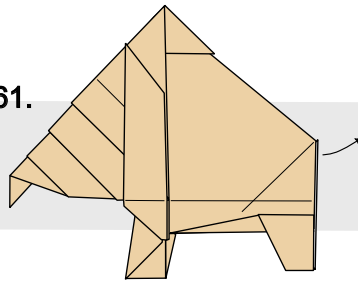

Pull out a bit of the tail
Tirer un peu de la queue

62.

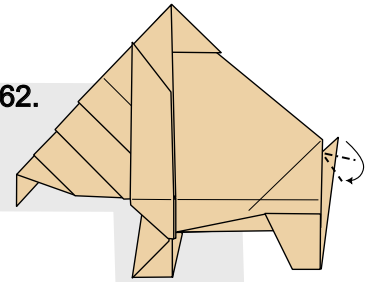

Squash fold
Pli écrasé

65.

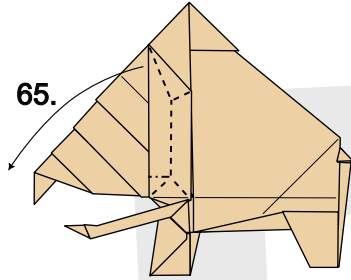

Narrow the upper tusk
and pull it to the left
*Amincir la défense du haut
et l'amener vers la gauche*

64.

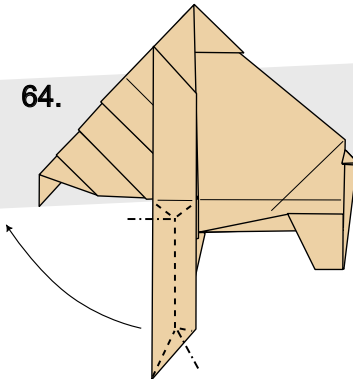

Narrow the lower tusk
and pull it to the left
*Amincir la défense du bas
et l'amener vers la gauche*

63.

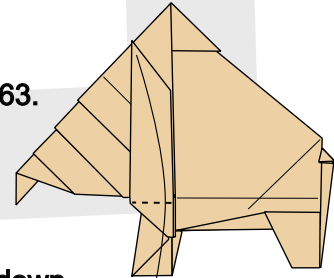

Fold down
one tusk
*Plier une défense
vers le bas*

66.

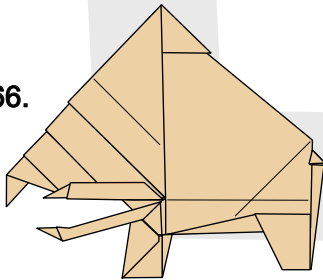

Repeat 63-65 behind
Répéter 63-65 derrière

67.

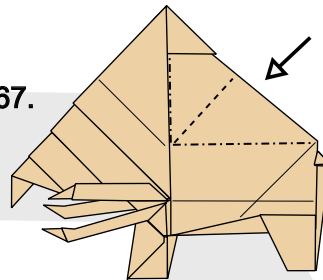

Push, making the model 3D
Enfoncer, rendant le modèle en 3D

68.

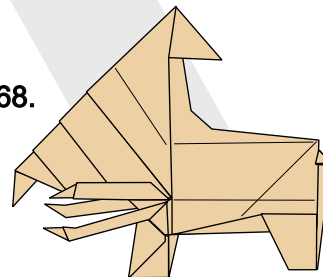

Model completed
Modèle terminé